

KEY 12X8X71

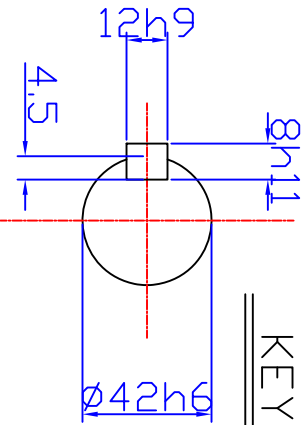

OUTPUT SHAFT

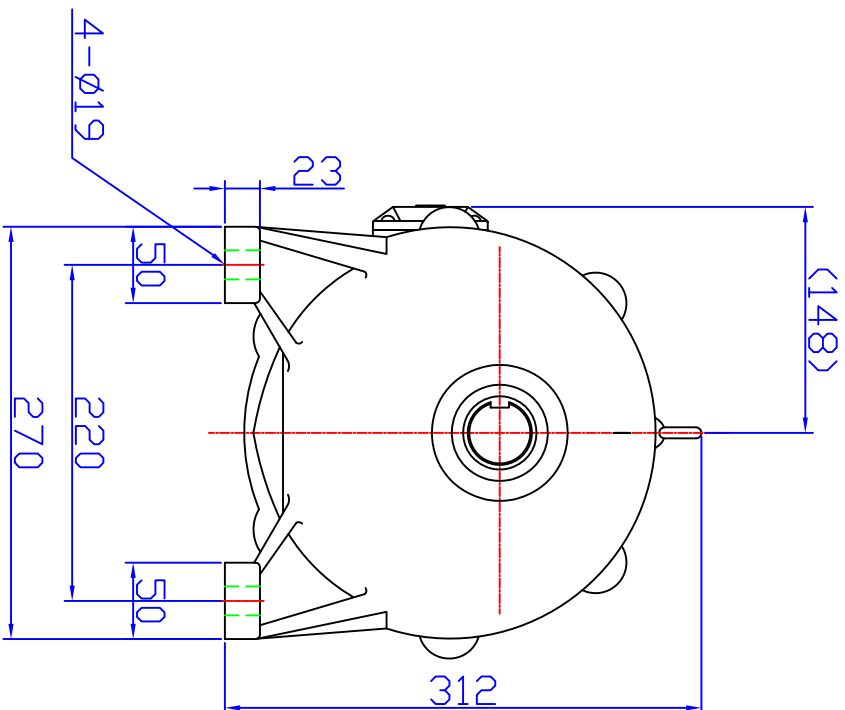

NO.	DESCRIPTION	MATERIAL	SIZE OR SPEC.	DATE
DRAWN	DESIGNED	CHECKED	APPROVED	SCALE
				1/1
				:M/M
NAME				DRAWN NO.
MF G42T-100RS1.5-4				REMARKS
OUTLINE DIM'S				
DRAWN NO.				
DSS2004-H				
DATE				
2006-04-01				



DAESUNG IND CO., LTD.
MECHINERY DIV.

*()안 치수는 변경될 수 있음.