

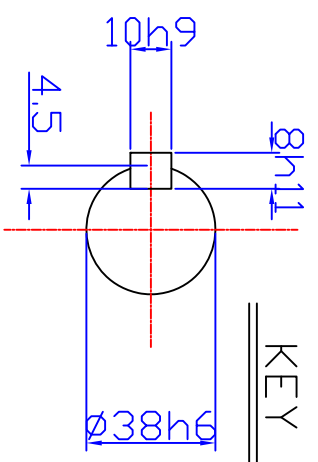

KEY 10X8X48

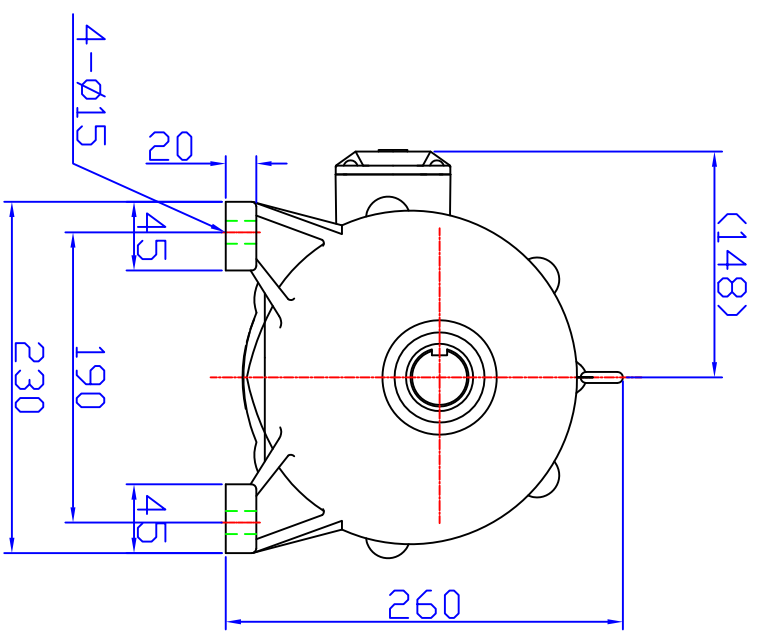

OUTPUT SHAFT



NO.	DESCRIPTION	MATERIAL	SIZE OR SPEC.	NAME
DRAWN	DESIGNED	CHECKED	APPROVED	SCALE
DATE	2006-04-01	 DAESUNG IND CO., LTD. MECHINERY DIV.		1/1
DROWN NO. REMARKS MF G38D-30RS1.5-4 OUTLINE DIM'S DRDW' NO. DSS2002-H				

*()안 치수는 변경될 수 있음.